

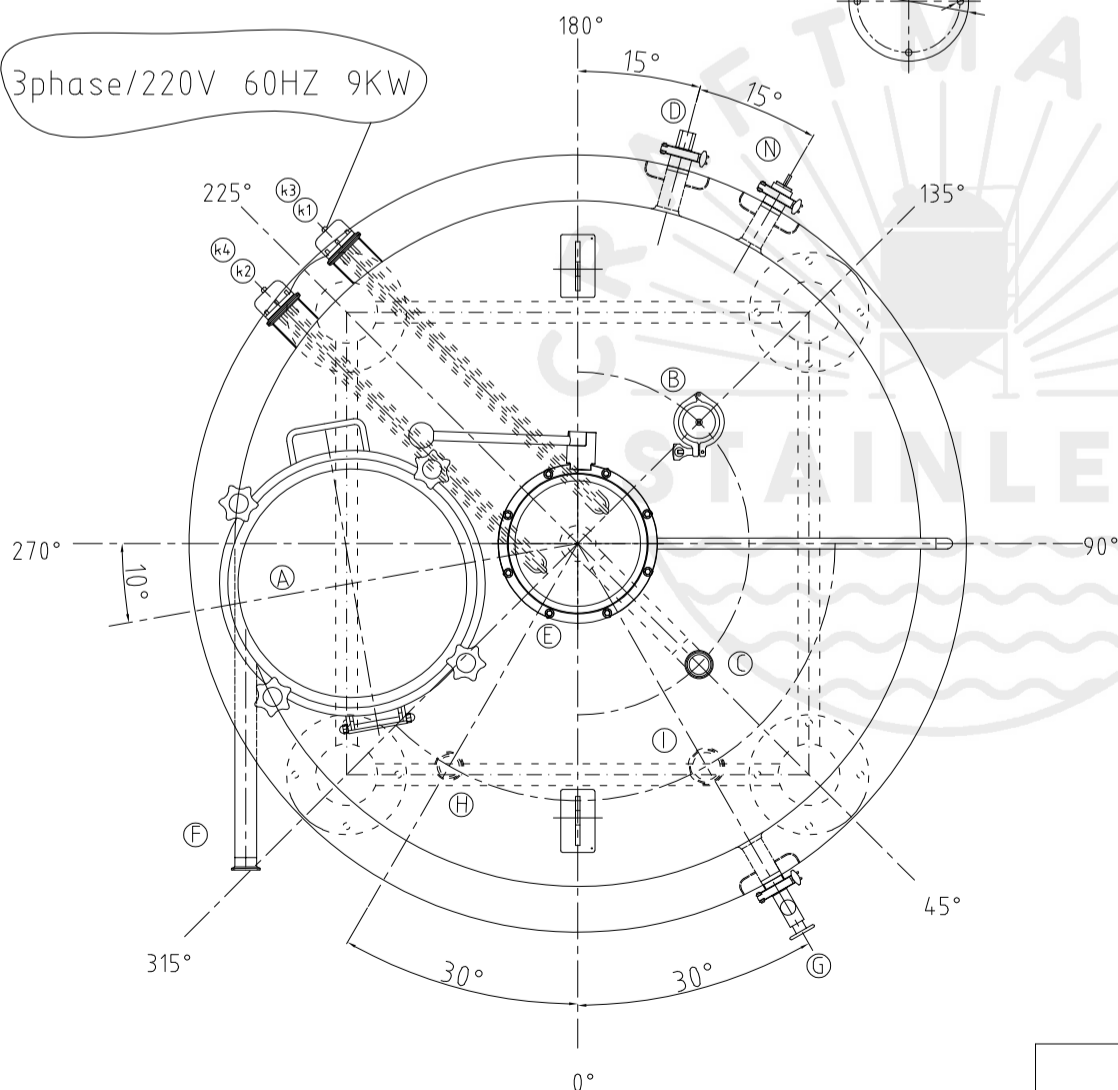

Design data	
Vessel category	Normal pressure
Description of parameter	Vessel
Working pressure psi	ATMP
Design pressure psi	ATMP
Level testing pressure psi	ATMP
Medium	Malt
Material	SUS 304
Working temperature °F	15 to 250
Design temperature °F	15 to 250
Gross volume BBL	9
Net volume BBL	7
Heat exchanger area m2	-----
Glycol Jacket Max Volume Gallon	-----
Insulation material	Chloride Free Polyurethane
Insulation thickness mm	80
Total Tank Weight Empty lbs	675
Total Tank Weight Full lbs	2485

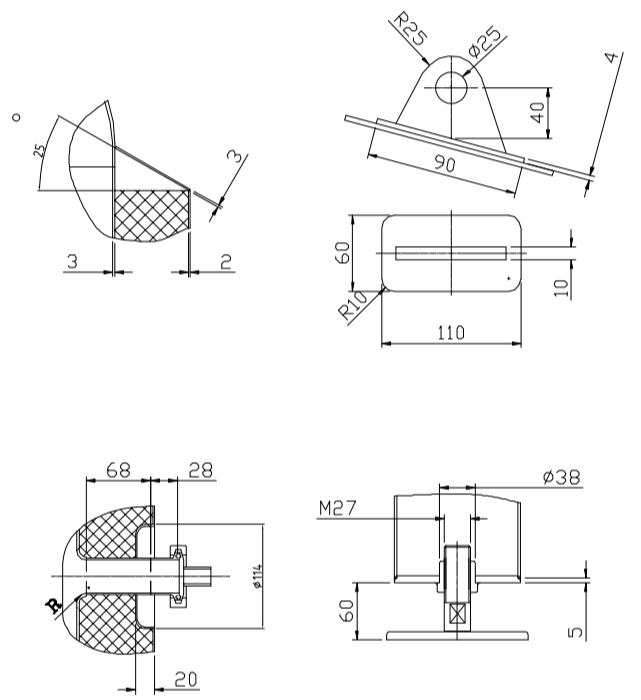

CONNECTIONS				
MARK	DN	DESCRIPTION	CONNECT SIZE	REMARKS
A	ø15.7"	Manway	ø400	ISO
B	2"	Light	ø50.8x15	ISO
C	1.5"	CIP APM FERRULE	ø38.1x15	ISO
D	1.5"	TEMPERATURE CONN	ø38.1x15	NPT
E	8"	EXHAUST CAP	ø203.2x3	ISO
F	1.5"	Roundabout	ø38.1x15	ISO
G	1.5"	LEVEL GAGE	ø38.1x15	ISO
H	1.5"	INLET	ø38.1x15	ISO
I	2"	OUTLET	ø50.8x15	ISO
J	2"	OUTLET	ø50.8x15	ISO
K	2.5"	Heating Rod Port	ø63.5x1.65	ISO
N	1.5"	Anti Dry Burning Sensor	ø38.1x15	ISO



02/28/2022

7BBL KW(EH)