

Design data

Vessel category		Normal pressure
Description of parameter		Vessel
Working pressure	psi	ATMP
Design pressure	psi	ATMP
Level testing pressure	psi	ATMP
Medium		Malt
Material		SUS 304
Working temperature	°F	15 to 250
Design temperature	°F	15 to 250
Gross volume	BBL	7
Net volume	BBL	5
Heat exchanger area	m2	1.9
Glycol Jacket Max Volume	Gallon	2.5
Insulation material		Chloride Free Polyurethane
Insulation thickness	mm	80
Total Tank Weight Empty	lbs	640
Total Tank Weight Full	lbs	1935

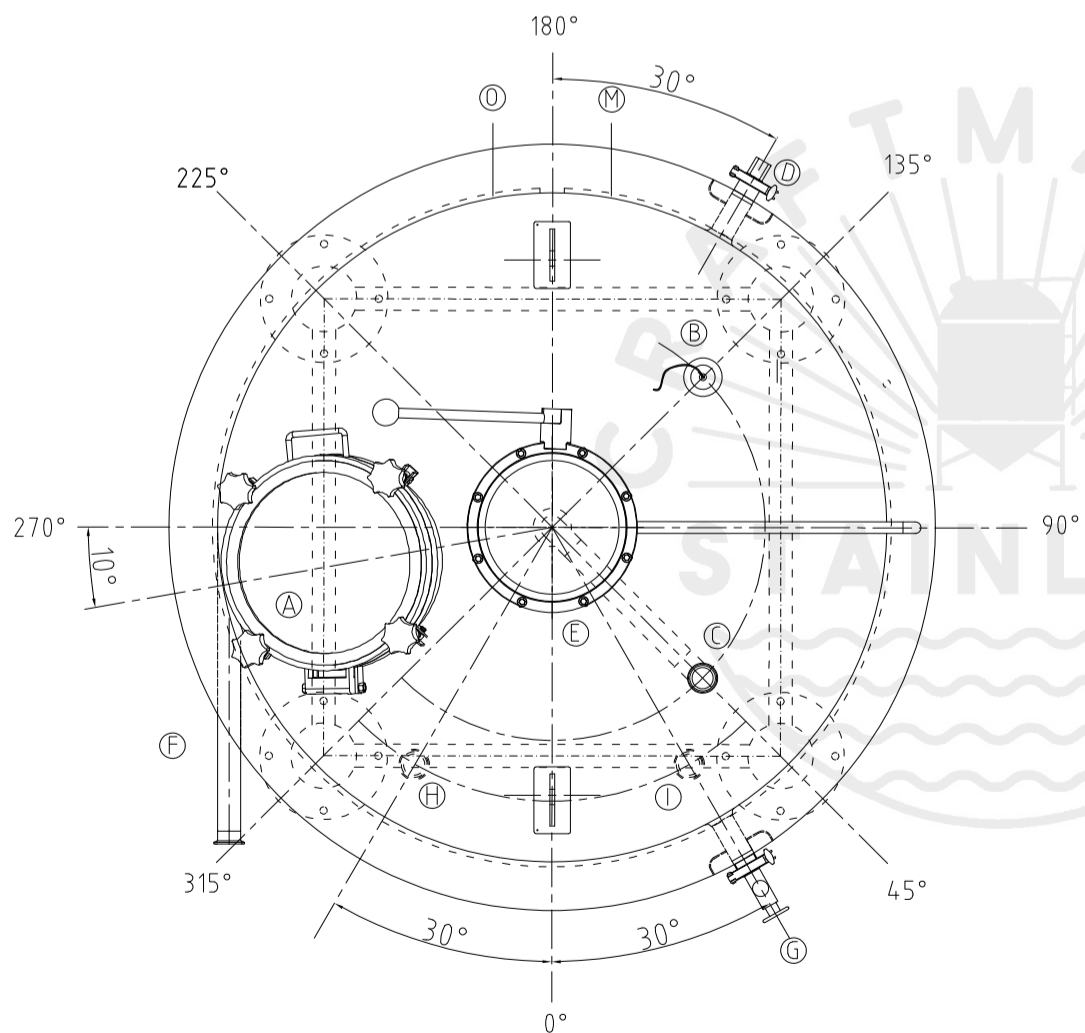
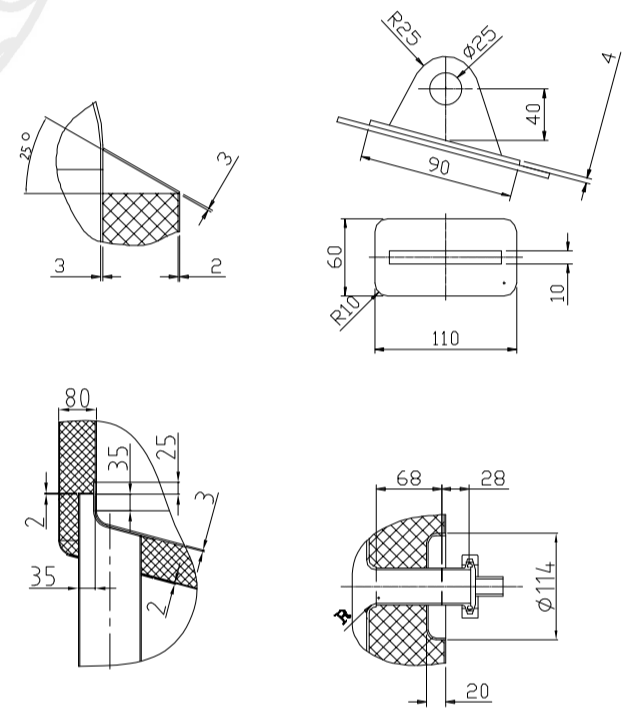
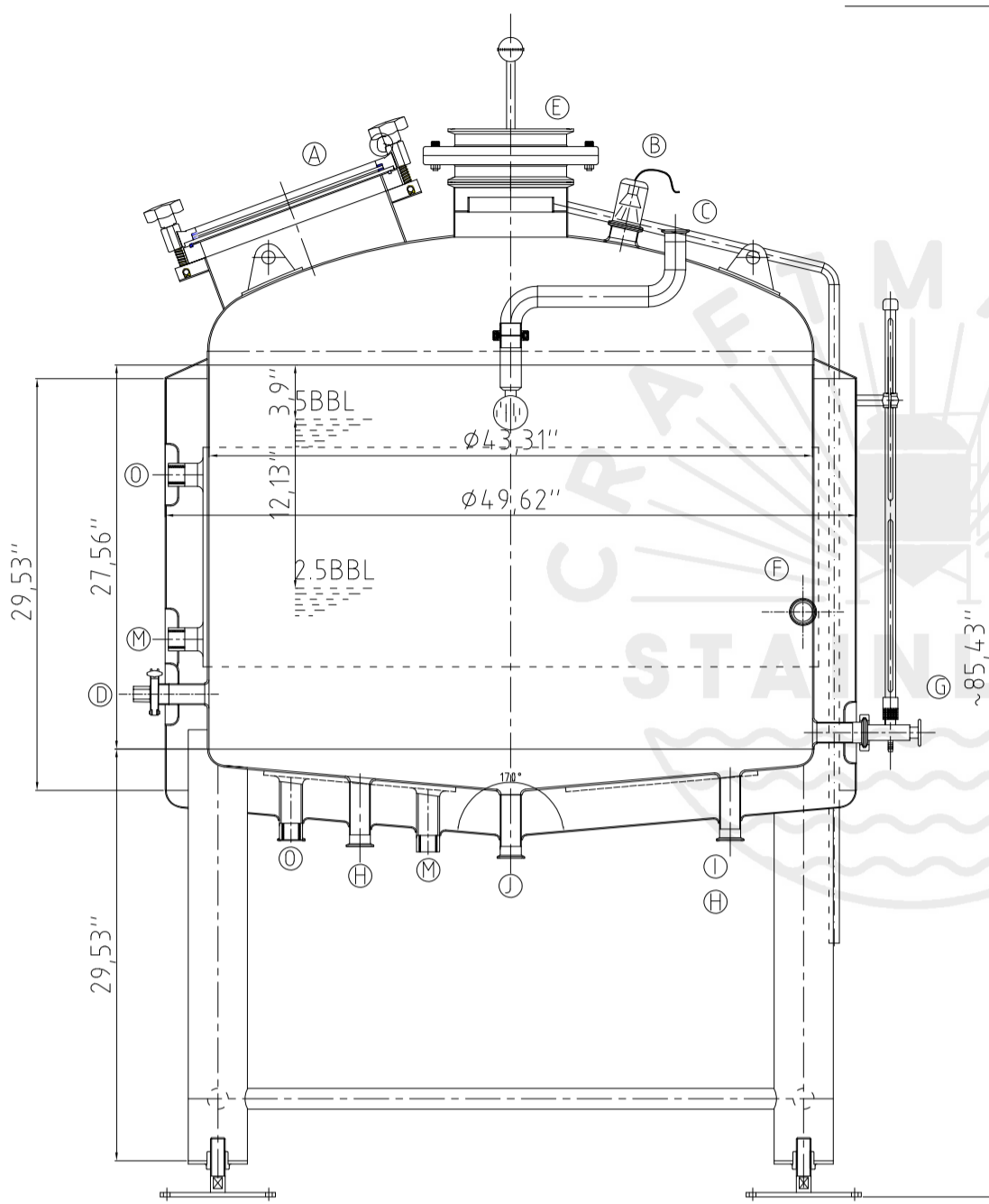

CONNECTIONS

MARK	DN	DESCRIPTION	CONNECT SIZE	REMARKS
A	Ø14"	Manway	Ø14"	ISO
B	2"	Light	2"	ISO
C	1.5"	CIP APM FERRULE	1.5"	ISO
D	1.5"	TEMPERATURE CONN	1.5"	NPT
E	8"	EXHAUST CAP	8"	ISO
F	1.5"	Roundabout	1.5"	ISO
G	1.5"	LEVEL GAGE	1.5"	ISO
H	1.5"	INLET	1.5"	ISO
I	1.5"	OUTLET	1.5"	ISO
J	1.5"	OUTLET	1.5"	ISO
M	3/4"	Steam Inlet	3/4"	NPT
O	3/4"	Steam Outlet	3/4"	NPT



02/28/2022

5BBL KW