

Design data	
Vessel category	Normal pressure
Description of parameter	Vessel
Working pressure	psi ATMP
Design pressure	psi ATMP
Level testing pressure	psi ATMP
Medium	Malt
Material	SUS 304
Working temperature	°F 15 to 250
Design temperature	°F 15 to 250
Gross volume	BBL 20
Net volume	BBL 15
Heat exchanger area	m2 4.6
Glycol Jacket Max Volume	Gallon 6.4
Insulation material	Chloride Free Polyurethane
Insulation thickness	mm 80
Total Tank Weight Empty	lbs 1165
Total Tank Weight Full	lbs 5045

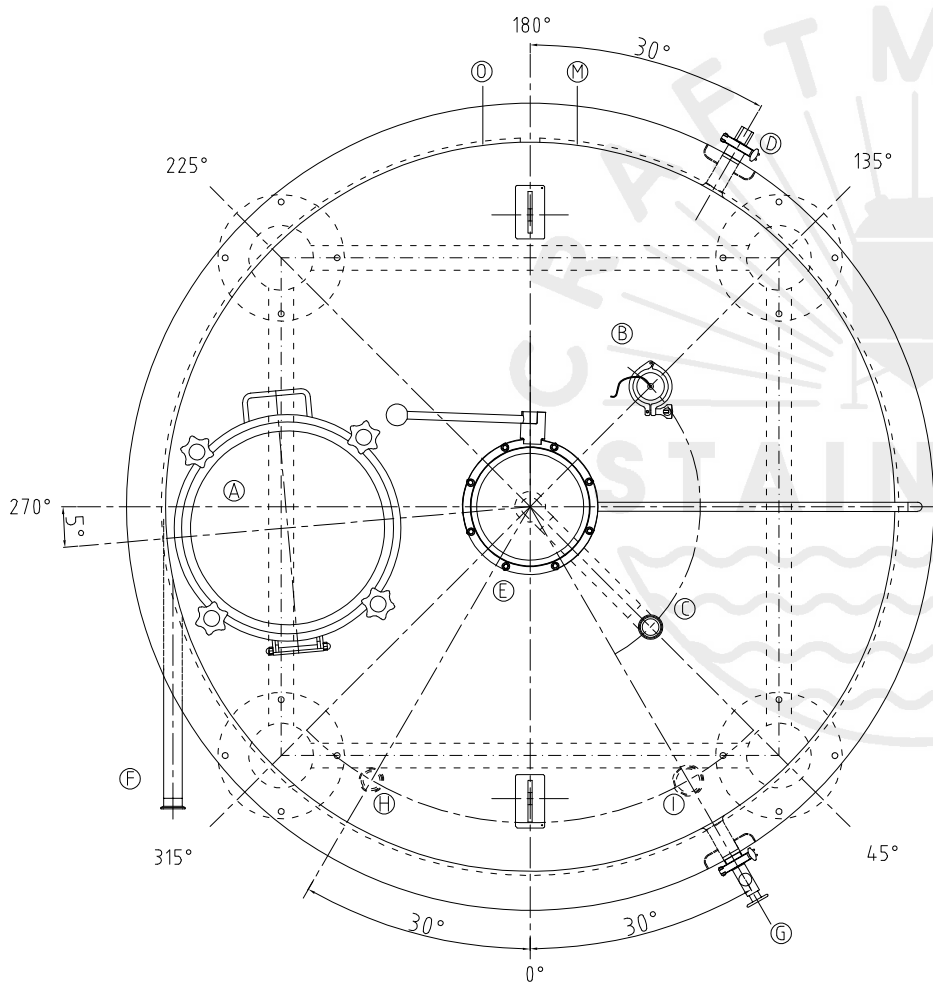

CONNECTIONS				
MARK	DN	DESCRIPTION	CONNECT SIZE	REMARKS
A	ø15.7"	Manway	ø15.7"	ISO
B	2"	Light	2"	ISO
C	1.5"	CIP APM FERRULE	1.5"	ISO
D	1.5"	TEMPERATURE CONN	1.5"	NPT
E	8"	EXHAUST CAP	8"	ISO
F	1.5"	Roundabout	1.5"	ISO
G	1.5"	LEVEL GAGE	1.5"	ISO
H	1.5"	INLET	1.5"	ISO
I	1.5"	OUTLET	1.5"	ISO
J	2"	OUTLET	2"	ISO
M	3/4"	Steam Inlet	3/4"	NPT
O	3/4"	Steam Outlet	3/4"	NPT

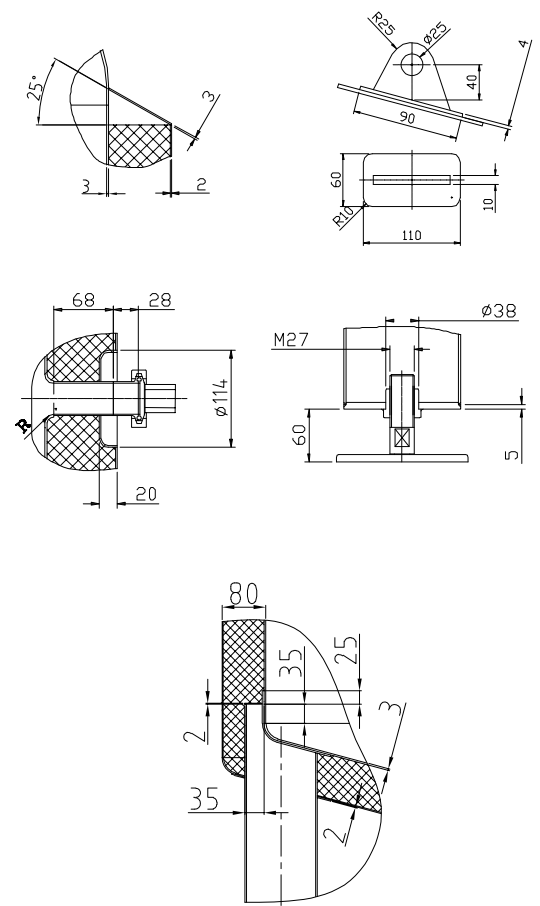

02/28/2022

15BBL KW
(STEAM)