

Design data		
Vessel category	Normal pressure	
Description of parameter	Vessel	Jacket
Working pressure	psi	22 / 45
Design pressure	psi	22 / 45
Level testing pressure	psi	45 / 60
Medium	Beer	Glycol
Material	SUS 304	SUS 304
Working temperature	°F 15 to 100	
Design temperature	°F 15 to 100	
Gross volume	BBL	12.3
Net volume	BBL	10
Heat exchanger area	m2	3.1
Glycol Jacket Max Volume	Gallon	4.3
Insulation material	Chloride Free Polyurethane	
Insulation thickness	mm	80
Total Tank Weight Empty	lbs	1870
Total Tank Weight Full	lbs	7120

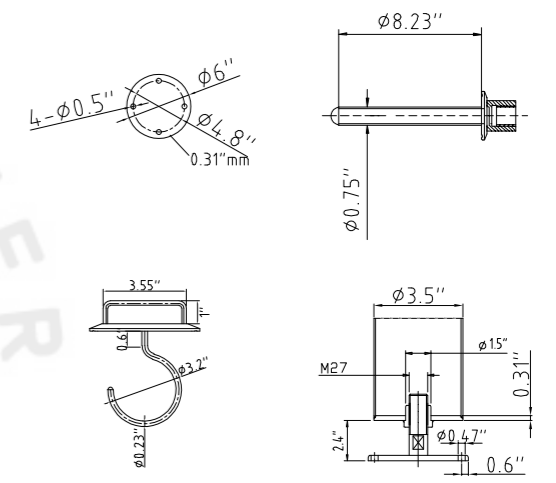

CONNECTIONS				
MARK	DN	DESCRIPTION	CONNECT SIZE	REMARKS
A	2"	PVRV FERRULE	2"	ISO
B	3"	PORT	3"	ISO
C	15"	CIP APM FERRULE	15"	ISO
D	15"	TEMPERATURE CONN	15"	ISO
E	15"	CO2 INLET	15"	ISO
F	15"	TEM-GAGE	15"	ISO
G	15"	SAMPLE FERRULE	15"	ISO
H	15"	DIAIN ARM COUPLING	15"	ISO
I	3/4"	DIAIN ARM COUPLING	3/4"	ISO
J	2"	OUTLET	2"	ISO
k	DIN63-15"	DRAIN FERRULE	DIN63-15"	ISO
l	3/4"	COOLING OUTLET	3/4"	NPT
m	3/4"	COOLING INLET	3/4"	NPT
N	4"	HOP PORT	4"	ISO
R	21"x17"	MANWAY	21"x17"	ISO



05/05/2023  
10BBL LAGERING TANK