

Design data

Vessel category	Normal pressure	
Description of parameter	Vessel	
Working pressure	psi	ATMP
Design pressure	psi	ATMP
Level testing pressure	psi	ATMP
Medium	Malt	
Material	SUS 304	
Working temperature	°F	15 to 250
Design temperature	°F	15 to 250
Gross volume	BBL	13
Net volume	BBL	10
Heat exchanger area	m ²	3.1
Glycol Jacket Max Volume	Gallon	4.3
Insulation material	Chloride Free Polyurethane	
Insulation thickness	mm	80
Total Tank Weight Empty	lbs	910
Total Tank Weight Full	lbs	3495

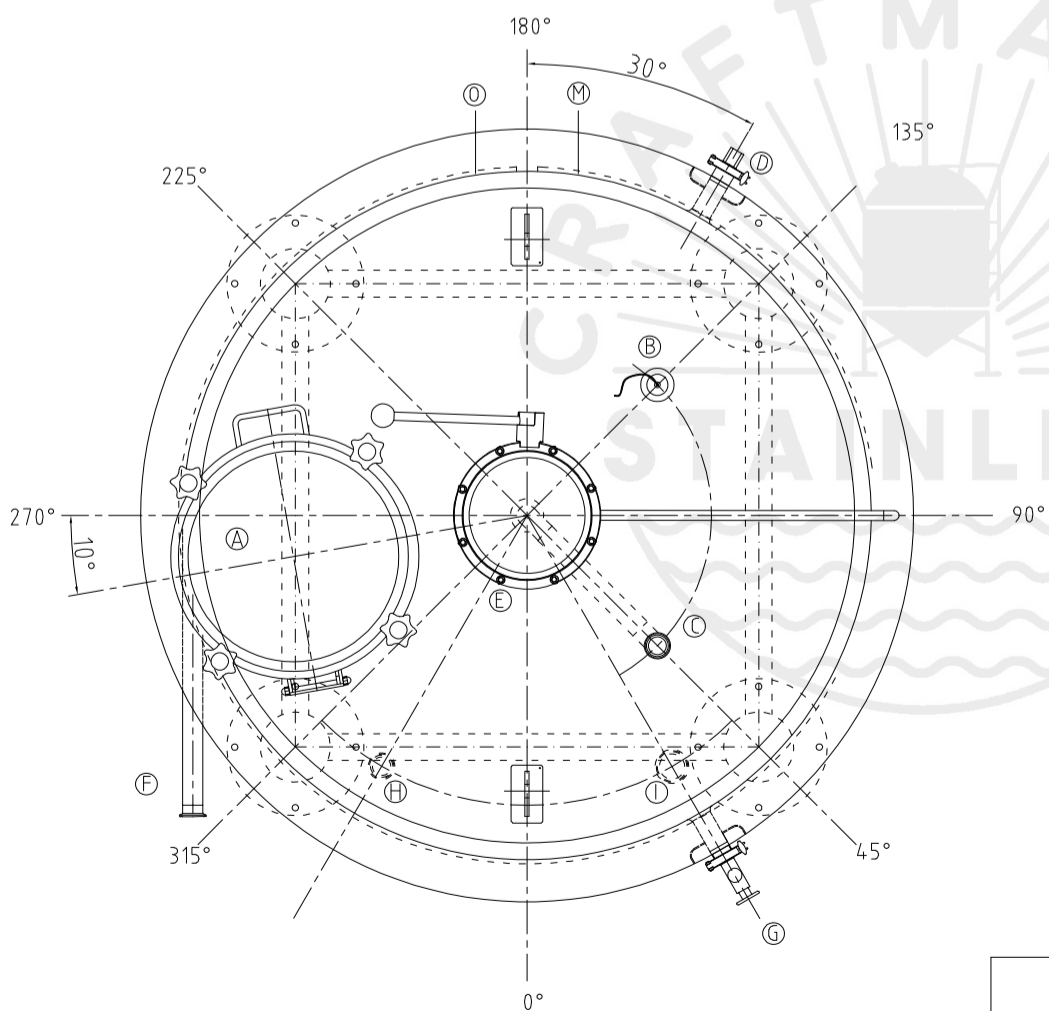
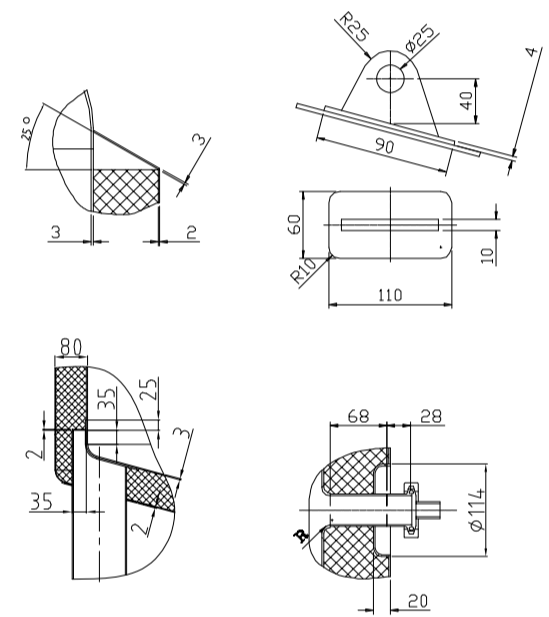
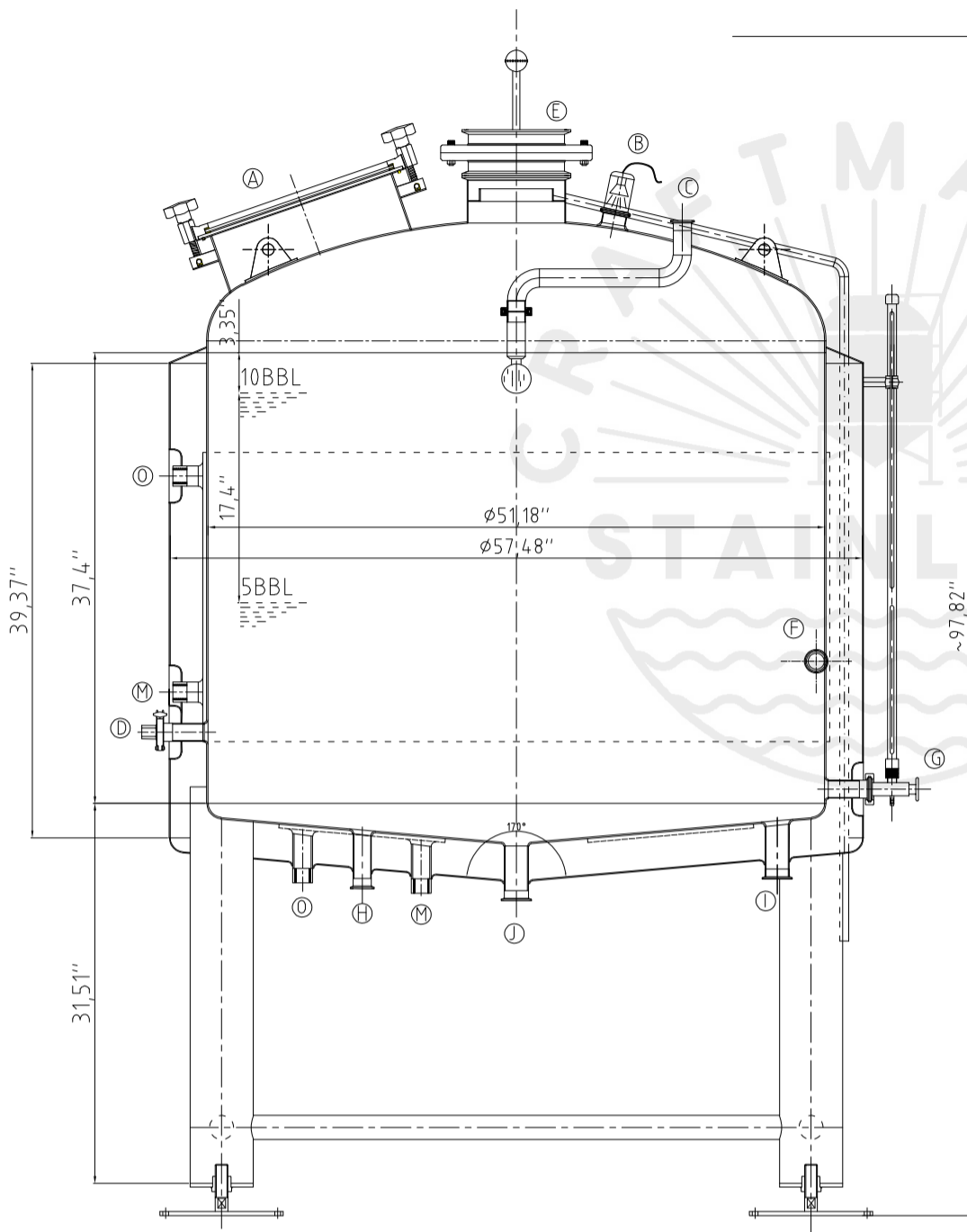

CONNECTIONS

MARK	DN	DESCRIPTION	CONNECT SIZE	REMARKS
A	ø15.7"	Manway	ø15.7"	ISO
B	2"	Light	2"	ISO
C	1.5"	CIP APM FERRULE	1.5"	ISO
D	1.5"	TEMPERATURE CONN	1.5"	NPT
E	8"	EXHAUST CAP	8"	ISO
F	1.5"	Roundabout	1.5"	ISO
G	1.5"	LEVEL GAGE	1.5"	ISO
H	1.5"	INLET	1.5"	ISO
I	1.5"	OUTLET	1.5"	ISO
J	2"	OUTLET	2"	ISO
M	3/4"	Steam Inlet	3/4"	NPT
O	3/4"	Steam Outlet	3/4"	NPT



02/28/2022

10BBL KW
(STEAM)